

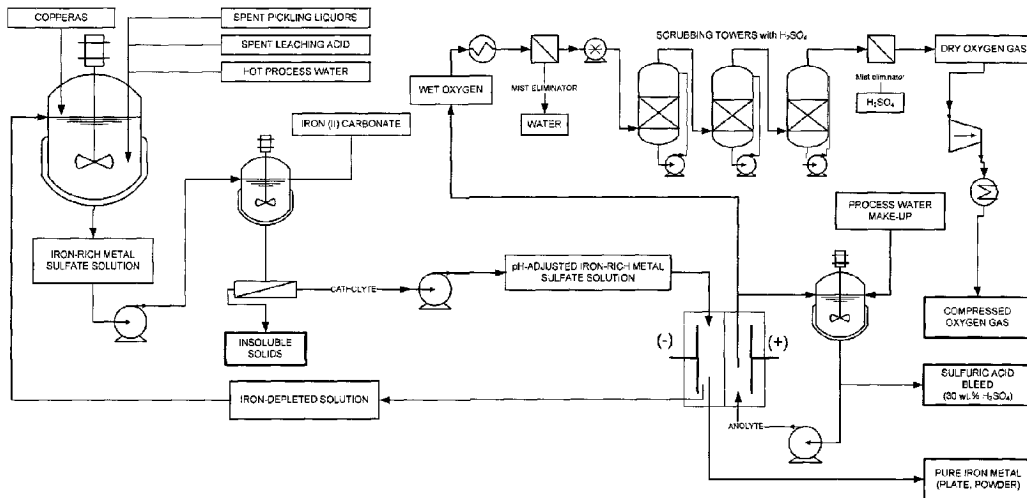

(86) **Date de dépôt PCT/PCT Filing Date:** 2009/04/14  
 (87) **Date publication PCT/PCT Publication Date:** 2009/10/15  
 (45) **Date de délivrance/Issue Date:** 2016/06/14  
 (85) **Entrée phase nationale/National Entry:** 2010/09/07  
 (86) **N° demande PCT/PCT Application No.:** CA 2009/000471  
 (87) **N° publication PCT/PCT Publication No.:** 2009/124393  
 (30) **Priorité/Priority:** 2008/04/11 (US61/044,282)

(51) **Cl.Int./Int.Cl. C25C 1/06** (2006.01),  
**C22B 3/04** (2006.01), **C23F 1/26** (2006.01),  
**C25B 1/02** (2006.01), **C25B 1/22** (2006.01),  
**C25B 11/04** (2006.01), **C25C 7/00** (2006.01)  
 (72) **Inventeur/Inventor:**  
 CARDARELLI, FRANCOIS, CA  
 (73) **Propriétaire/Owner:**  
 ELECTROCHEM TECHNOLOGIES & MATERIALS INC.,  
 CA  
 (74) **Agent:** BENOIT & COTE INC.

(54) **Titre : PROCÉDE ELECTROCHIMIQUE DE RECUPERATION DE VALEURS DE FER METALLIQUE ET D'ACIDE SULFURIQUE A PARTIR DE DECHETS SULFATES RICHES EN FER, DE RESIDUS D'EXPLOITATION ET DE LESSIVES DEDECAPAGE.**  
 (54) **Title: ELECTROCHEMICAL PROCESS FOR THE RECOVERY OF METALLIC IRON AND SULFURIC ACID VALUES FROM IRON-RICH SULFATE WASTES, MINING RESIDUES AND PICKLING LIQUORS**



(57) **Abrégé/Abstract:**

An electrochemical process for the recovery of metallic iron or an iron-rich alloy, oxygen and sulfuric acid from iron-rich metal sulfate wastes is described. Broadly, the electrochemical process comprises providing an iron-rich metal sulfate solution; electrolyzing the iron-rich metal sulfate solution in an electrolyzer comprising a cathodic compartment equipped with a cathode having a hydrogen over-potential equal or higher than that of iron and containing a catholyte having a pH below about 6.0; an anodic compartment equipped with an anode and containing an anolyte; and a separator allowing for anion passage; and recovering electrodeposited iron or iron-rich alloy, sulfuric acid and oxygen gas. Electrolyzing the iron-rich metal sulfate solution causes iron or an iron-rich alloy to be electrodeposited at the cathode, nascent oxygen gas to evolve at the anode, sulfuric acid to accumulate in the anodic compartment and an iron depleted solution to be produced.

## (12) INTERNATIONAL APPLICATION PUBLISHED UNDER THE PATENT COOPERATION TREATY (PCT)

(19) World Intellectual Property Organization  
International Bureau(43) International Publication Date  
15 October 2009 (15.10.2009)(10) International Publication Number  
**WO 2009/124393 A1**

## (51) International Patent Classification:

C25C 1/06 (2006.01) C25B 1/22 (2006.01)  
C22B 3/04 (2006.01) C25B 11/04 (2006.01)  
C23F 1/26 (2006.01) C25C 7/00 (2006.01)  
C25B 1/02 (2006.01)

## (21) International Application Number:

PCT/CA2009/000471

## (22) International Filing Date:

14 April 2009 (14.04.2009)

## (25) Filing Language:

English

## (26) Publication Language:

English

## (30) Priority Data:

61/044,282 11 April 2008 (11.04.2008) US

## (71) Applicant and

(72) Inventor: **CARDARELLI, François** [CA/CA]; 230 rue des Carouges, Terrebonne, Québec J6V 1M2 (CA).(74) Agents: **PRINCE, Gaétan** et al.; BCF LLP, 1100 René-Lévesque Blvd. West, 25th Floor, Montréal, Québec H3B 5C9 (CA).

(81) Designated States (unless otherwise indicated, for every kind of national protection available): AE, AG, AL, AM, AO, AT, AU, AZ, BA, BB, BG, BH, BR, BW, BY, BZ, CA, CH, CN, CO, CR, CU, CZ, DE, DK, DM, DO, DZ, EC, EE, EG, ES, FI, GB, GD, GE, GH, GM, GT, HN, HR, HU, ID, IL, IN, IS, JP, KE, KG, KM, KN, KP, KR, KZ, LA, LC, LK, LR, LS, LT, LU, LY, MA, MD, ME, MG, MK, MN, MW, MX, MY, MZ, NA, NG, NI, NO, NZ, OM, PG, PH, PL, PT, RO, RS, RU, SC, SD, SE, SG, SK, SL, SM, ST, SV, SY, TJ, TM, TN, TR, TT, TZ, UA, UG, US, UZ, VC, VN, ZA, ZM, ZW.

(84) Designated States (unless otherwise indicated, for every kind of regional protection available): ARIPO (BW, GH, GM, KE, LS, MW, MZ, NA, SD, SL, SZ, TZ, UG, ZM, ZW), Eurasian (AM, AZ, BY, KG, KZ, MD, RU, TJ, TM), European (AT, BE, BG, CH, CY, CZ, DE, DK, EE, ES, FI, FR, GB, GR, HR, HU, IE, IS, IT, LT, LU, LV, MC, MK, MT, NL, NO, PL, PT, RO, SE, SI, SK, TR), OAPI (BF, BJ, CF, CG, CI, CM, GA, GN, GQ, GW, ML, MR, NE, SN, TD, TG).

## Published:

— with international search report (Art. 21(3))

(54) Title: ELECTROCHEMICAL PROCESS FOR THE RECOVERY OF METALLIC IRON AND SULFURIC ACID VALUES FROM IRON-RICH SULFATE WASTES, MINING RESIDUES AND PICKLING LIQUORS

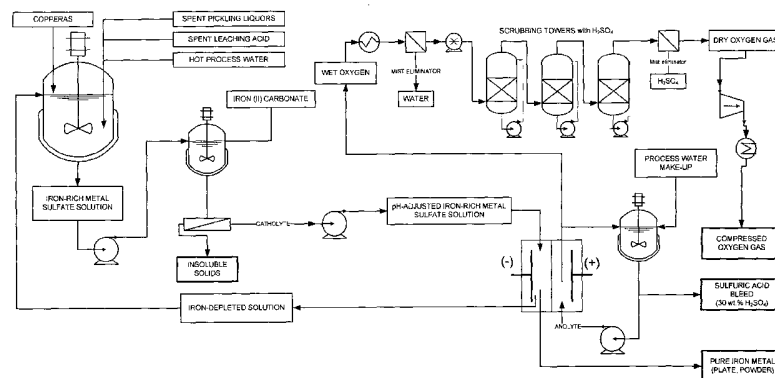

Figure 1

(57) Abstract: An electrochemical process for the recovery of metallic iron or an iron-rich alloy, oxygen and sulfuric acid from iron-rich metal sulfate wastes is described. Broadly, the electrochemical process comprises providing an iron-rich metal sulfate solution; electrolyzing the iron-rich metal sulfate solution in an electrolyzer comprising a cathodic compartment equipped with a cathode having a hydrogen over-potential equal or higher than that of iron and containing a catholyte having a pH below about 6.0; an anodic compartment equipped with an anode and containing an anolyte; and a separator allowing for anion passage; and recovering electrodeposited iron or iron-rich alloy, sulfuric acid and oxygen gas. Electrolyzing the iron-rich metal sulfate solution causes iron or an iron-rich alloy to be electrodeposited at the cathode, nascent oxygen gas to evolve at the anode, sulfuric acid to accumulate in the anodic compartment and an iron depleted solution to be produced.

**TITLE**

ELECTROCHEMICAL PROCESS FOR THE RECOVERY OF METALLIC IRON AND SULFURIC ACID VALUES FROM IRON-RICH SULFATE WASTES, MINING RESIDUES AND PICKLING LIQUORS

**FIELD**

[0001] The present invention relates to an electrochemical process for the recovery of metallic iron, iron rich alloys, oxygen and sulfuric acid values from iron-rich metal sulfate wastes. More specifically, but not exclusively, the present invention relates to an electrochemical process for the recovery of metallic iron, iron rich alloys, oxygen and sulfuric acid from iron-rich metal sulfate wastes such as copperas, iron-rich sulfate liquors, spent sulfuric acid leaching liquors, pickling liquors, or any other iron-rich metal sulfate liquor or solution such as those by-produced in the mining, metallurgical, chemical and titanium dioxide pigment industries.

**BACKGROUND**

[0002] In the white titanium dioxide pigment manufacture by the sulfate process, a titanium-rich feedstock (*e.g.*, ilmenite, titanium slag) is first dried to a moisture content of less than 0.1 wt.%. The dried raw material is then ground in a ball mill to a mean particle size of about 40  $\mu\text{m}$ . If titanium slag is used, the minute amount of free metallic iron is removed by means of magnetic separation to prevent hazardous hydrogen gas evolution during the subsequent digestion.

[0003] A batch digestion step is subsequently performed in which the ground material (*e.g.*, ilmenite, titanium slag, or a blend) is mixed with concentrated sulfuric acid (93-98 wt.%  $\text{H}_2\text{SO}_4$ ). The acid number (the mass ratio of sulfuric acid to raw material) is chosen such that the final ratio of  $\text{H}_2\text{SO}_4$  to  $\text{TiO}_2$  in a subsequent

hydrolysis step is about 1.8. The reaction is usually started by injecting superheated steam. The initial temperature rises up to about 70°C which is mainly due to the enthalpy of hydration of the sulfuric acid. The temperature further increases to about 220°C due to the enthalpy released by the sulfation reaction itself. The mixture is allowed to remain at about 220°C for several hours.

[0004] The reaction cake is then dissolved in cold water to avoid premature hydrolysis. If titanium slag is used, the trivalent titanium cations ( $\text{Ti}^{3+}$ ) (because of the negative standard electrode potential of the redox couple [ $E_{298.15\text{K}}^0(\text{TiO}^{2+}/\text{Ti}^{3+}) = -0.100$  V/SHE]) reduce all the ferric iron ( $\text{Fe}^{3+}$ ) [ $E_{298.15\text{K}}^0(\text{Fe}^{3+}/\text{Fe}^{2+}) = +0.710$  V/SHE] according to the redox reaction:  $\text{Ti}^{3+} + \text{Fe}^{3+} + \text{H}_2\text{O} \rightarrow \text{TiO}^{2+} + \text{Fe}^{2+} + 2\text{H}^+$ . With ilmenite, scrap iron metal (Fe) must be added to reduce all the ferric cations according to the redox reaction:  $\text{Fe}_{(s)}^0 + \text{Fe}^{3+} \rightarrow 2\text{Fe}^{2+}$ .

[0005] The solution is then allowed to clarify by settling and filtered using a rotary vacuum filter to remove any undissolved residues. The clarified liquor contains about 200-300 g/L of titanium sulfate ( $\text{TiOSO}_4$ ) and about 30-50 g/L of total iron when only titanium slag is used. However, up to 120-150 g/L of total iron is present in the solution when ilmenite is used (following the reduction of the ferric cations by the addition of scrap metallic iron). The iron rich solution is cooled to allow for the crystallization of iron (II) sulfate heptahydrate ( $\text{FeSO}_4 \cdot 7\text{H}_2\text{O}$ ), called *copperas* or *melanterite* when it is found in nature as a mineral.

[0006] The remaining depleted liquor contains about 170-230 g/L  $\text{TiO}_2$ , 20-30 g/L iron and 20-28 wt.%  $\text{H}_2\text{SO}_4$ . The titanium oxyhydrate is precipitated by hydrolysis at 95-110°C, filtered, washed, dried, doped with pigmentary additives and finally calcined at 800-1100°C to produce the desired white pigment. Following the hydrolysis, the spent liquor contains about 20 wt.%  $\text{H}_2\text{SO}_4$  and about 20-30 g/L iron.

[0007] When ilmenite is used as feedstock, significant amounts of copperas and iron-rich sulfate liquors are generated as by-products. These by-products may mostly comprise ferrous sulfate and spent sulfuric acid or a combination thereof. The actual by-products are in fact more complex as these consist of a waste which is essentially made of the above salts contaminated with other metal sulfates if washing of the copperas crystals is not complete.

[0008] Commercialization of copperas as a flocculating agent in the treatment of wastewater or as an additive in cement to prevent the hazards related to hexavalent chromium is hampered by the important volume of the product compared to its iron content and its low market value. Therefore, harvesting iron as a metal and recovering sulfuric acid from the sulfate wastes greatly reduces the management of wastes and its associated costs.

[0009] Until now, except for dialysis and solvent extraction that were used to recover the spent sulfuric acid from pickling liquors, no electrochemical process has been used to recover both metallic iron and sulfuric acid from wastes by-produced in the titanium dioxide pigment industry.

[0010] It appears from the prior art that extensive work has been done since the second half of the eighteenth century on the electrodeposition of iron metal from iron-containing solutions. In fact, various processes for electroplating or electrorefining iron metal are known. Usually, the aim of these processes is to prepare an electrolytic iron metal of high purity and to a lesser extent pure iron metal powders. Usually, the most common electrolytes were based on iron (II) chloride [1] and on iron (II) sulfate [2] or a mixture of both.

[0011] Most of these known electrochemical processes were originally designed to electrodeposit iron metal at the cathode while the anodic reaction usually

consisted in the anodic dissolution of a soluble anode made of impure iron, pig iron, mild steel in bulk form or in pieces or turnings contained in a bag made of glass cloth, or synthetic fabrics such as Orlon® and Dynel® in order to retain the insoluble sludge. In such processes, the use of consumable-type anodes ensured a continuous supply of ferrous cations to the bath and avoided undesirable anodic reactions such as the evolution of corrosive nascent oxygen that normally occurs in sulfate electrolytes [3, 4].

**[0012]** None of these processes provided for the efficient simultaneous recovery of iron and sulfuric acid from iron-rich metal sulfate solutions. The only attempt to recover iron metal electrolytically from an iron-bearing sulfate solution was the Pyror process, which has been reviewed recently [5]. In this process, the iron-rich sulfate liquor was electrolyzed in a two compartment electrolyzer comprising steel cathodes, lead anodes and diaphragms made of various fabric materials. Owing to the low concentration of ferrous iron (25 g/L Fe) in the catholyte, sodium sulfate decahydrate was added as a supporting electrolyte to reach a final concentration of about 90-100 g/L Na<sub>2</sub>SO<sub>4</sub>. The anolyte was composed of 55-60 g/L sulfuric acid, 55-65 g/L sodium sulfate and 25 g/L ferric iron. The electrolysis was performed at a temperature ranging from 70°C to 80°C under a low current density of 250 A/m<sup>2</sup>, with an overall cell voltage of 3.75V and a cathodic current efficiency of 85%.

**[0013]** The major limitations of this process are the following: (1) a low space time yield of 0.260 kg.m<sup>-2</sup>h<sup>-1</sup> because of the low current density; (2) the impossibility of recovering pure sulfuric acid from the anolyte because of the presence of sodium sulfate which has to be removed and the contamination by ferric iron, lead, antimony and tin; and (3) the high specific energy consumption of 4.25 kWh/kg for the iron metal due to the elevated cell voltage reported.

**[0014]** In view of the strict specifications regarding the impurity content of sulfuric acid, the above drawbacks have prevented the use of such a process for the

recovery of iron and sulfuric acid values from iron-rich sulfate wastes by-produced during the manufacture of titanium dioxide pigment. The only alternative to electrolysis has been the recovery of sulfuric acid and iron by means of solvent extraction [6]. However, up to the present time, such a process has never reached a commercially useful scale because of the prohibitive cost of the organic solvents involved.

[0015] There remains a need for an efficient and economical process for recovering both iron metal and sulfuric acid values from iron-rich metal sulfate wastes, especially those by-produced in the titanium pigment industry.

### **SUMMARY**

[0016] The present invention broadly relates to an electrochemical process for the recovery of metallic iron or an iron-rich alloy, oxygen and sulfuric acid from iron-rich metal sulfate wastes.

[0017] As broadly claimed, the present invention relates to an electrochemical process for the recovery of metallic iron or an iron-rich alloy, oxygen and sulfuric acid from an iron-rich metal sulfate solution, the process comprising:

[0018] providing an iron-rich metal sulfate solution;

[0019] electrolysing the iron-rich metal sulfate solution in an electrolyser comprising: a cathodic compartment equipped with a cathode having a hydrogen over-potential equal or higher than that of iron and containing a catholyte having a pH below about 6.0; an anodic compartment equipped with an anode and containing an anolyte; and a separator allowing for anion passage; and

[0020] recovering electrodeposited iron or iron-rich alloy, sulfuric acid and oxygen gas;

[0021] wherein electrolyzing the iron-rich metal sulfate solution causes iron or iron-rich alloy to be electrodeposited at the cathode, nascent oxygen gas to evolve at the anode, sulfuric acid to accumulate in the anodic compartment and an iron depleted solution to be produced.

[0022] In an embodiment of the present invention, the step of providing an iron rich metal sulfate solution comprises leaching an iron rich feedstock. In a further embodiment of the present invention, the step of providing an iron rich metal sulfate solution comprises dissolving copperas into acidified water. In yet a further embodiment of the present invention, the iron-rich feedstock is selected from the group consisting of copperas and iron sulfates by-produced during the manufacture of titanium dioxide pigment, iron-rich mining residues such as by produced in the manufacture of synthetic rutiles and iron ores. In yet a further embodiment of the present invention, the iron-rich metal sulfate solution is obtained either by leaching or dissolving iron ores and concentrates in spent sulfuric acid or spent pickling liquors that contain free sulfuric acid. Non-limiting examples of iron ores and concentrates comprise oxides, carbonates and sulfides.

[0023] In an embodiment of the present invention, the pH of the catholyte is adjusted to a pH ranging from about 0.5 to about 6. In a further embodiment of the present invention, the pH of the catholyte is adjusted to a pH ranging from about 1.0 to about 5.0. In a further embodiment of the present invention, the pH of the catholyte is adjusted to a pH ranging from about 1.5 to about 4.5. In a further embodiment of the present invention, the pH of the catholyte is adjusted to a pH ranging from about 2.0 to about 4.0.



[0024] In an embodiment of the present invention, the cathode has an overvoltage for the discharge of the hydrogen cation at  $200 \text{ A.m}^{-2}$  of greater than about 466 mV in  $0.5 \text{ mol.dm}^{-3} \text{ H}_2\text{SO}_4$  solution at  $25^\circ\text{C}$  and an overvoltage for the discharge of the hydrogen cation at  $1000 \text{ A.m}^{-2}$  of greater than about 800 mV in  $1.0 \text{ mol.dm}^{-3} \text{ H}_2\text{SO}_4$  solution at  $25^\circ\text{C}$ .

[0025] In an embodiment of the present invention, the cathode comprises a material or is coated with a material selected from the group consisting of nickel, nickel alloy, iron, iron alloy, titanium, titanium alloy, zirconium, zirconium alloy, zinc, zinc alloy, cadmium, cadmium alloy, tin, tin alloy, copper, copper alloy, lead, lead alloy, niobium, niobium alloy, gold, gold alloy, mercury and a metallic amalgam including mercury.

[0026] In an embodiment of the present invention, the electrolyzing step is performed in a two-compartment electrolyser comprising an ion exchange membrane separating the anodic compartment from the cathodic compartment.

[0027] In an embodiment of the present invention, the electrolyzing step is performed in a three-compartment electrolyser comprising a central compartment disposed between the anodic compartment and the cathodic compartment and wherein an ion exchange membrane separates the anodic and cathodic compartments from the central compartment.

[0028] The foregoing and other objects advantages and features of the present invention will become more apparent upon reading of the following non-restrictive description of specific embodiments thereof, given by way of example only with reference to the accompanying drawings.

**BRIEF DESCRIPTION OF THE DRAWINGS**

[0029] In the appended drawings:

[0030] **Figure 1** is a flow-sheet diagram illustrating the various steps of the electrochemical process according to a first embodiment of the present invention, based on a two-compartment electrolyser and performing the electrolysis with a pH-adjusted iron-rich metal sulfate solution.

[0031] **Figure 2** is a flow-sheet diagram illustrating the various steps of the electrochemical process according to a second embodiment of the present invention, based on a three-compartment electrolyser and performing the electrolysis with a pH-adjusted iron-rich metal sulfate solution.

[0032] **Figure 3** is a schematic illustration of a two-compartment electrolyser used in some embodiments of the present invention illustrating the electrochemical reactions occurring at the electrodes.

[0033] **Figure 4** is a schematic illustration of a three-compartment electrolyser used in some embodiments of the present invention illustrating the electrochemical reactions occurring at the electrodes.

[0034] **Figure 5** is a schematic illustration of a two-compartment electrolyser in accordance with a further embodiment of the present invention.

**DESCRIPTION**

[0035] In order to provide a clear and consistent understanding of the terms used in the present specification, a number of definitions are provided below. Moreover, unless defined otherwise, all technical and scientific terms as used herein have the same meaning as commonly understood to one of ordinary skill in the art to which this invention pertains.

[0036] The use of the word “a” or “an” when used in conjunction with the term “comprising” in the claims and/or the specification may mean “one”, but it is also consistent with the meaning of “one or more”, “at least one”, and “one or more than one”. Similarly, the word “another” may mean at least a second or more.

[0037] As used in this specification and claim(s), the words “comprising” (and any form of comprising, such as “comprise” and “comprises”), “having” (and any form of having, such as “have” and “has”), “including” (and any form of including, such as “include” and “includes”) or “containing” (and any form of containing, such as “contain” and “contains”), are inclusive or open-ended and do not exclude additional, unrecited elements or process steps.

[0038] The term “about” is used to indicate that a value includes an inherent variation of error for the device or the method being employed to determine the value.

[0039] Various iron-rich feedstocks may be used in the process of the present invention, including, but not limited to, iron-rich sulfate wastes, for example from the digestion in sulfuric acid of titaniferous ores, spent acid leaching liquors, pickling liquors or any other iron-rich metal sulfate liquor or solution. The feedstock may be solid, anhydrous, in slurry form or in solution. In an embodiment of the present

invention, the iron-rich feedstock is selected from the group consisting of copperas and iron sulfates by-produced during the manufacture of titanium dioxide pigment, iron-rich mining residues such as by produced in the manufacture of synthetic rutiles and iron ores. Non-limiting examples of iron ores comprise oxides, carbonates and sulfides. In yet a further embodiment of the present invention, the iron-rich metal sulfate solution is obtained by dissolution of copperas and/or iron sulfates into process water or into iron-rich spent pickling solutions. In yet a further embodiment of the present invention, the iron-rich metal sulfate solutions is obtained from mixtures of iron-rich spent pickling solutions and spent sulfuric acid solutions originating from various industrial processes. In yet a further embodiment of the present invention, the iron-rich metal sulfate solutions are obtained by iron metal and alloy scraps dissolved in spent sulfuric acid or spent pickling liquors that contain free sulfuric acid. In yet a further embodiment of the present invention, the iron-rich metal sulfate solutions are obtained either by leaching or dissolving iron ores or concentrates such as iron oxides, iron carbonates and iron sulfides in spent sulfuric acid or spent pickling liquors that contain free sulfuric acid.

**[0040]** As used herein, the term “electrolyser” generally designates a two-compartment or three-compartment electrolyser. The electrolysers used in the process of the present invention comprise an anodic compartment and a cathodic compartment, separated by an ion exchange membrane.

**[0041]** As used herein, when referring to an electrolyser, the term “non-anodic compartment” designates the cathodic compartment of a two-compartment electrolyser and/or the central compartment of a three-compartment electrolyser. For more clarity, it does not designate the cathodic compartment of a three-compartment electrolyser.

**[0042]** As used herein, the term over-potential (also known as over-voltage) generally designates, according to the definition given by Gerischer, the difference

between the electrical potential of an electrode under the passage of current and the thermodynamic value of the electrode potential in the absence of electrolysis for the same experimental conditions.

**[0043]** As used herein, when referring to a cathode, the term “hydrogen over-potential” designates an over-potential associated with the discharge of hydrogen cations at the cathode, liberating nascent hydrogen gas. A cathode having high hydrogen over-potential minimizes hydrogen evolution during electrolysis, and thus facilitates the electrodeposition of iron. Known and non-limiting examples of materials having high hydrogen over-potential are given, for example, in Cardarelli [7]. Advantageously, the cathode material also allows stripping of the iron metal deposit. Non limiting examples of suitable cathode materials include iron, steels, nickel, nickel alloy, titanium (of commercial or higher purity), titanium alloy (for example titanium palladium ASTM grade 7), zirconium (of commercial or higher purity), zirconium alloy, zinc (of commercial or higher purity), zinc alloy, cadmium (of commercial or higher purity), cadmium alloy, tin (of commercial or higher purity), tin alloy, copper (of commercial or higher purity), copper alloy, lead (of commercial or higher purity), lead alloy, niobium (of commercial or higher purity), niobium alloy, gold (of commercial or higher purity), gold alloy, mercury or metallic amalgam with mercury. It is to be understood that a cathode having high hydrogen over-potential may consist of a bulk of a material having high hydrogen over-potential or may simply be coated with such a material.

**[0044]** As used herein, when qualifying a cathode, the expression “having a hydrogen over-potential equal or higher than that of iron” means that, in absolute value, the cathode has an over-voltage at  $200 \text{ A.m}^{-2}$  greater than about 466 mV in  $0.5 \text{ mol.dm}^{-3}$   $\text{H}_2\text{SO}_4$  at  $25^\circ\text{C}$  and at  $1000 \text{ A.m}^{-2}$  greater than about 800 mV in  $1.0 \text{ mol.dm}^{-3}$   $\text{H}_2\text{SO}_4$  at  $25^\circ\text{C}$ .

**[0045]** In an embodiment, wherein the feedstock is in solid and/or anhydrous form, the process of the present invention generally consists in first leaching or dissolving the feedstock, such as copperas ( $\text{FeSO}_4 \cdot 7\text{H}_2\text{O}$ ) by-produced during the digestion in sulfuric acid of titania-rich feedstocks (*e.g.*, ilmenite, titanium slag) with either one of: a) hot acidic process water; b) hot diluted sulfuric acid; c) hot spent iron rich liquors coming from the high pressure leaching with sulfuric acid of reduced and/or metallized titanium feedstocks such in the processes used to produce synthetic rutiles (*e.g.*, Becher, Benelite) or from the high pressure leaching with sulfuric acid of titanium slags or even from spent liquors by-produced during the pickling of steels. After complete dissolution, the pH is adjusted by adding, for instance, but not restricted to iron (II) carbonate, the liquor is filtered to separate the remaining insoluble solids, mostly ferric hydroxide,  $\text{Fe}(\text{OH})_3$ .

**[0046]** In another embodiment, wherein the feedstock is already in the form of a slurry, the leaching may help dissolve any soluble iron sulfates before solid-liquid separation. The solid separation step is typically performed by a physical separation method, non-limiting examples of which include decantation, filtration or centrifugation. In an embodiment of the present invention, the solid-liquid separation is performed by means of filtration.

**[0047]** In still another embodiment, wherein the feedstock is in a clear aqueous liquid form, *i.e.* that of an iron-rich metal sulfate solution, the leaching or dissolving steps, or the acid-leaching of reduced and/or metallized titanium feedstocks such as in the processes used to produce synthetic rutiles, are of no particular interest.

**[0048]** Two main process variants can be used for recovering sulfuric acid, oxygen and metal values from the iron-rich metal sulfate solution, based on the same general principle of simultaneous recovery of metallic iron and sulfuric acid values from an iron-rich metal sulfate solution by electrolysis, using a catholyte adjusted to a

pH below 6.0 and a cathode having a hydrogen over-potential equal or higher than that of iron.

**[0049]** In an embodiment of the present invention, the cathode is etched prior to beginning the electrolysis. In a further embodiment of the present invention, the cathode is etched using an oxalic acid solution (10 wt.%). In yet a further embodiment of the present invention the cathode is etched using a fluoro-nitric acid mixture. In yet a further embodiment of the present invention, the fluoro-nitric acid mixture comprises about 70 vol% conc. HNO<sub>3</sub>, about 20 vol.% conc. HF and about 10 vol.% H<sub>2</sub>O. Other etching solutions are known in the art, and are within the capacity of a skilled technician.

**[0050]** In a particular embodiment of the process of the present invention, as illustrated in **Figure 1**, the pH of the iron-rich metal sulfate solution is first adjusted to from about 0.5 to about 6.0, with alkaline reagents such as, but not limited to, iron (II) carbonate or ammonium hydroxide or a mixture thereof, after which the solution is ready for electrolysis.

**[0051]** Still with reference to **Figure 1**, the electrolytic stage consists in circulating the pH-adjusted iron-rich metal sulfate solution inside the cathodic compartment of an electrolyser. The iron-rich metal sulfate solution thus acts as a catholyte. In an embodiment, the electrolyser comprises two compartments separated by an anion-exchange membrane (as illustrated in **Figure 3**). The cathodic compartment comprises a cathode made of nickel, nickel alloy, iron, steel, titanium or a titanium alloy (usually ASTM grade 7), while the anodic compartment has a dimensionally stable anode with an iridium dioxide coating for promoting the evolution of oxygen (DSA<sup>TM</sup>-O<sub>2</sub>) for instance Ti-Pd/IrO<sub>2</sub> or preferably Ta/IrO<sub>2</sub>. In an embodiment of the present invention, the anolyte that circulates in a loop within the anodic compartment comprises a mixture of about 30 wt.% sulfuric acid. It was

observed that at this concentration the anolyte exhibits excellent ionic conductivity at several temperatures (e.g., 83 S/m at 25°C and 101 S/m at 50°C).

**[0052]** During electrolysis at the above-mentioned pH ranging from about 0.5 to about 6.0, iron metal deposits at the cathode. Sulfate anions migrate through the permeable anion exchange membrane towards the anodic compartment, where water is oxidized to yield nascent oxygen gas at the surface of the anode and leaving behind hydronium cations that increase the acidity of the anodic compartment according to the following electrochemical reactions:

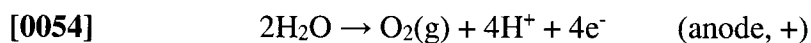
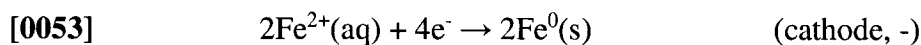

**[0055]** The overall reaction therefore being the production of iron metal at the cathode, and oxygen gas and sulfuric acid being produced in the anodic compartment:

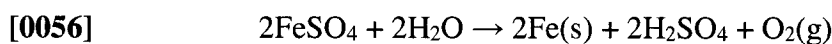

**[0057]** Side-reactions may also occur:

**[0058]** (1) At the anode, the oxidation of sulfate anions forming persulfate anions [e.g., peroxomonosulfate ( $\text{SO}_5^{2-}$ ) and peroxodisulfate ( $\text{S}_2\text{O}_8^{2-}$ ) anions] which yield at high current densities and low temperature, under the acidic process conditions encountered in the anodic compartment, a needle-like precipitate of two highly unstable persulfuric acids [e.g., peroxomonosulfuric acid or Caro's acid ( $\text{H}_2\text{SO}_5$ ) and peroxodisulfuric acid or Marshall acid ( $\text{H}_2\text{S}_2\text{O}_8$ )]:



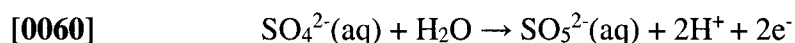
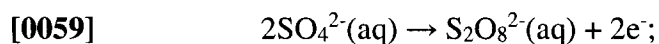

[0061] (2) At the cathode, the evolution of hydrogen gas:



[0063] along with the reduction of traces of ferric cations present in the catholyte:

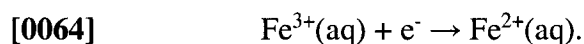

[0065] On the cathode side, these undesired side reactions are minimized by maintaining the pH of the catholyte above about 0.5 and below a pH of about 6.0 and by using a cathode material having a high over-potential for the discharge of hydrogen cations so as to prevent hydrogen evolution. In an embodiment, the cathode materials used in the process of the present invention have a hydrogen over-potential equal to or higher (in absolute value) than that of pure iron in given electrolysis conditions. In an embodiment of the present invention, the pH of the catholyte is maintained between about 0.5 and about 6.0. In a further embodiment of the present invention, the pH of the catholyte is maintained between about 1.0 and about 5.0. In yet a further embodiment of the present invention, the pH of the catholyte is maintained between about 1.5 and about 4.5. In yet a further embodiment of the present invention, the pH of the catholyte is maintained between about 2.0 and about 4.0. Therefore, the precipitation of ferric hydroxide that occurs can be continuously removed by filtration. Only traces of ferric cations remain in solution, in equilibrium with the insoluble hydroxide. In addition,

using an inert atmosphere (*e.g.* nitrogen) above the cathodic compartment may help in preventing the oxidation of the ferrous cations.

[0066] On the anode side, maintaining a temperature above room temperature and limiting the anodic current density impedes the formation of persulfuric acids, thereby ensuring the safe operation and production of a high purity sulfuric acid.

[0067] In an embodiment of the present invention, the electrolysis is conducted at a temperature ranging between about 20°C to about 80°C under galvanostatic control. The overall current density is comprised between about 200 to about 10,000 A/m<sup>2</sup> with a cell voltage ranging from about 1.5 to about 5.0 V per cell. In this specific embodiment, the faradaic efficiency is usually greater than about 90% and the average specific energy consumption ranges between about 1.60 to about 5.33 kWh per kg of iron.

[0068] The oxygen gas evolved is released to the atmosphere or it is recovered by conventional methods. For example, as shown in **Figure 1**, it may be recovered by suction, eventually cooled by passing it through a heat exchanger, and dried by passing it through a mist eliminator and several concentrated sulfuric acid spray-towers (scrubbing). Finally the dry and cold oxygen gas may be compressed, thus being ready to be transported or stored on-site for future use.

[0069] In the embodiment where plates of electrodeposited iron metal are produced, the electrodeposits are mechanically stripped from the cathode(s) (*e.g.* titanium, nickel or steel cathodes) at the end of the electrolysis. The iron metal plate is thoroughly rinsed with slightly acidic water to remove traces of catholyte and are eventually passivated with nitric acid, rinsed with deionized water and dried under a nitrogen atmosphere.

**[0070]** In the embodiment where pure iron metal chips are electrodeposited onto a rotating mandrel, they can be mechanically continuously removed from the poorly adhering titanium, nickel or steel drum cathodes by means of a scraper. The harvested iron metal chips are thoroughly rinsed with slightly acidic water to remove traces of catholyte and are eventually passivated with nitric acid, rinsed with deionized water and dried under a nitrogen atmosphere. A comminution treatment can subsequently be performed to obtain fine iron metal powder.

**[0071]** In the embodiment where fine iron powder is produced, it can be mechanically continuously removed from the poorly adhering titanium, nickel or steel cathodes by the intense circulation of catholyte and harvested using one or more hydrocyclone(s) in series and/or using permanent magnets installed at the underflow of the hydrocyclones. The harvested iron metal powder is thoroughly rinsed with slightly acidic water to remove traces of catholyte and is eventually passivated with nitric acid, rinsed with deionized water and dried under a nitrogen atmosphere.

**[0072]** In an embodiment of the present invention, an iron-rich alloy, in the form of a plate, chips or powder is produced. The alloy typically comprises reducible metallic elements that were co-deposited with the iron metal. Non-limiting examples of such reducible metals include Ni, Co, Cu, Cd, Sn, Mn, Cr or V. Other reducible elements are known in the art, and are within the capacity of a skilled technician.

**[0073]** In an embodiment of the present invention, salts, non-limiting examples of which include lithium, sodium, potassium and ammonium sulfates are added to the catholyte in order to increase the electrical conductivity thereof.

**[0074]** During the electrolysis, sulfate anions migrate through the anion exchange membrane towards the anode where the oxidation of water yields nascent oxygen gas and leaves behind hydronium cations in the anodic compartment of the

electrolyzer. Therefore, the concentration of sulfuric acid in the anolyte increases continuously over time. When the acid concentration reaches a predetermined threshold value, pure water is added to the system in order to re-establish the original anolyte acid concentration. The addition of water increases the total volume of the anolyte. A bleed is thus performed in the anolyte circuit loop following the water addition.

[0075] In practice, the maximum threshold concentration of sulfuric acid is established based on the following experimental observation: at a given operating temperature, the conductivity of the sulfuric acid first increases with concentration then reaches a maximum and then decreases again. The highest concentration of acid, at which the ionic conductivity again equals the conductivity of the original acid concentration, is used as the upper threshold limit. For instance, at 50°C, starting with 30 wt.% sulfuric acid having a conductivity of 108.9 S/m, the conductivity increases up to 109.75 S/m for a concentration of 33 wt.% and then decreases down to 108.75 S/m for 36 wt.% H<sub>2</sub>SO<sub>4</sub> while at 60°C. Therefore, 36 wt.% H<sub>2</sub>SO<sub>4</sub> can be selected as the cut-off value. Once the cut-off value is reached, water is added until the acid concentration, as measured by means of a hydrometer, once again reaches 30 wt.%. The excess volume of sulfuric acid at 30 wt.% is removed and recycled back to the process (*e.g.*, pickling, acid-pressure leaching), or its concentration can be further increased by usual techniques used to concentrate sulfuric acid, such as for instance but not restricted to, evaporation, evaporation under reduced pressure or vacuum, mechanical vapor recompression (MVR), reverse osmosis, dialysis, etc.

[0076] In an embodiment of the present invention, following the electrolysis, the depleted iron solution is replenished by adding copperas in order to bring the total iron concentration to a suitable level and then recirculated into the cathodic compartment of the electrolyzer.

[0077] It is to be understood that changing the pH of the catholyte in the process of **Figure 1**, for example from 2.5 to 3.5 by adding iron (II) carbonate, would allow any unwanted ferric cations to precipitate as insoluble ferric hydroxide,  $\text{Fe}(\text{OH})_3$ , forming a sludge that can be easily continuously removed by filtration.

[0078] In an embodiment of the process of the present invention, as illustrated in **Figure 2**, the iron-rich metal sulfate solution is sent without any prior treatment (such as pH adjustment) to the electrochemical plant. The electrolyser design used in this process (as illustrated in **Figure 4**) comprises three compartments: (i) a cathodic compartment comprising a cathode; (ii) an anodic compartment comprising a dimensionally stable anode for the evolution of oxygen; and (iii) a central compartment separated from the cathodic compartment by a cation-exchange membrane and from the anodic compartment by an anion exchange membrane. In an embodiment, the cathodic compartment comprises an iron, steel, nickel or titanium plate cathode. The catholyte circulating within the cathodic compartment comprises a saturated solution of ferrous sulfate (about 600 g/L  $\text{FeSO}_4 \cdot 7\text{H}_2\text{O}$ ), while the anolyte comprises about 30 wt.% sulfuric acid. The pH of the catholyte is adjusted below 6.0. In an embodiment of the present invention, the pH of the catholyte is maintained between about 1.0 and about 5.0. In yet a further embodiment of the present invention, the pH of the catholyte is maintained between about 1.5 and about 4.5. In yet a further embodiment of the present invention, the pH of the catholyte is maintained between about 2.0 and about 4.0. In yet a further embodiment of the present invention, the pH of the catholyte is maintained between about 2.5 and about 3.5. The iron-rich metal sulfate solution is continuously passed through the central compartment. During the electrolysis (**Figure 5**), ferrous cations of the iron-rich metal sulfate solution migrate through the cation exchange membrane and are reduced to pure iron metal on the nickel, iron or titanium cathode while the sulfate anions migrate through the anion exchange membrane towards the dimensionally stable anode where water is oxidized, thereby producing nascent oxygen

gas, leaving behind hydronium cations that combine with the incoming sulfate anions forming additional sulfuric acid. The electrochemical reactions involved are as follows:

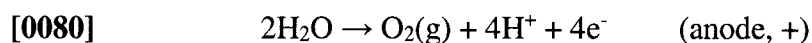
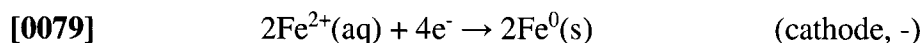

[0081] The overall reaction therefore being the production of iron metal at the cathode, and oxygen and sulfuric acid in the anodic compartment:

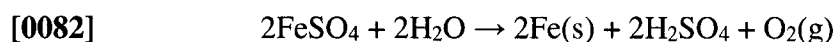

[0083] Side-reactions may also occur.

[0084] (1) At the anode, the oxidation of sulfate anions forming persulfate anions [*e.g.*, peroxomonosulfate ( $\text{SO}_5^{2-}$ ) and peroxydisulfate ( $\text{S}_2\text{O}_8^{2-}$ ) anions] which yield at high current densities and low temperature, under the acidic process conditions encountered in the anodic compartment, a needle-like precipitate of two highly unstable persulfuric acids [*e.g.*, peroxomonosulfuric acid or Caro's acid ( $\text{H}_2\text{SO}_5$ ) and peroxydisulfuric acid or Marshall acid ( $\text{H}_2\text{S}_2\text{O}_8$ )]:

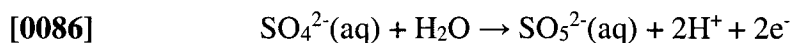
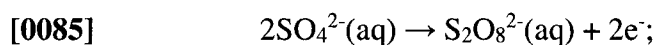

[0087] (2) At the cathode, the evolution of hydrogen gas:



[0089] along with the reduction of traces of ferric cations present in the catholyte:

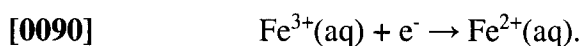

[0091] On the cathode side, these undesired side reactions are minimized by maintaining the pH of the catholyte above about 0.5 and below a pH of about 6.0 and by using a cathode material having a high over-potential for the discharge of hydrogen cations so as to prevent hydrogen evolution. In an embodiment, the cathode materials used in the process of the present invention have a hydrogen over-potential equal to or higher (in absolute value) than that of iron in given electrolysis conditions. In an embodiment of the present invention, the pH of the catholyte is maintained between about 0.5 and about 6.0. In a further embodiment of the present invention, the pH of the catholyte is maintained between about 1.0 and about 5.0. In yet a further embodiment of the present invention, the pH of the catholyte is maintained between about 1.5 and about 4.5. In yet a further embodiment of the present invention, the pH of the catholyte is maintained between about 2.0 and about 4.0. Therefore, the precipitation of ferric hydroxide that occurs can be continuously removed by filtration. Only traces of ferric cations remain in solution, in equilibrium with the insoluble hydroxide. In addition, using an inert atmosphere (*e.g.* nitrogen) above the cathodic compartment may help in preventing the oxidation of the ferrous cations.

[0092] On the anode side, maintaining a temperature above room temperature and limiting the anodic current density impedes the formation of persulfuric acids, thereby ensuring the safe operation and production of a high purity sulfuric acid.

[0093] In an embodiment of the present invention, the electrolysis is conducted at a temperature ranging between about 20°C to about 80°C under

galvanostatic control. The overall current density is comprised between about 200 to about 10,000 A/m<sup>2</sup> with a cell voltage ranging from about 1.5 to about 5.0 V per cell. In this specific embodiment, the faradaic efficiency is usually greater than about 90% and the average specific energy consumption is between about 1.60 to about 5.33 kWh per kg of iron.

[0094] The oxygen gas evolved is released to the atmosphere or it is recovered by conventional methods. For example, as shown in **Figure 2**, it may be recovered by suction, eventually cooled by passing it through a heat exchanger, and dried by passing it through a mist eliminator and several concentrated sulfuric acid spray-towers (scrubbing). Finally the dry and cold oxygen gas may be compressed, thus being ready to be transported or stored on-site for future use.

[0095] In the embodiment where plates of electrodeposited iron metal are produced, they plates mechanically stripped from the cathode(s) (*e.g.* titanium, nickel or steel cathodes) at the end of the electrolysis. The iron metal plate is thoroughly rinsed with slightly acidic water to remove traces of catholyte and are eventually passivated with nitric acid, rinsed with deionized water and dried under a nitrogen atmosphere.

[0096] In the embodiment where pure iron metal chips are electrodeposited onto a rotating mandrel, they can be mechanically continuously removed from the poorly adhering titanium, nickel or steel drum cathodes by means of a scraper. The harvested iron metal chips are thoroughly rinsed with slightly acidic water to remove traces of catholyte and are eventually passivated with nitric acid, rinsed with deionized water and dried under a nitrogen atmosphere. A comminution treatment can subsequently be performed to obtain fine iron metal powder.

[0097] In an embodiment of the present invention, an iron-rich alloy, in the form of a plate, chips or powder is produced. The alloy typically comprises reducible



metallic elements that were co-deposited with the iron metal. Non-limiting examples of such reducible metals include Ni, Co, Cu, Cd, Sn, Mn, Cr or V. Other reducible elements are known in the art, and are within the capacity of a skilled technician.

**[0098]** In an embodiment of the present invention, salts, non-limiting examples of which include lithium, sodium, potassium and ammonium sulfates are added to the catholyte in order to increase the electrical conductivity thereof.

**[0099]** In the embodiment where fine iron powder is produced, it can be mechanically continuously removed from the poorly adhering titanium, nickel or steel cathodes by the intense circulation of catholyte and harvested using one or more hydrocyclone(s) in series and/or using permanent magnets installed at the underflow of the hydrocyclones. The harvested iron metal powder is thoroughly rinsed with slightly acidic water to remove traces of catholyte and is eventually passivated with nitric acid, rinsed with deionized water and dried under a nitrogen atmosphere.

**[00100]** During the electrolysis, sulfate anions migrate through the anion exchange membrane towards the anode where the oxidation of water yields nascent oxygen gas and leaves behind hydronium cations in the anodic compartment of the electrolyzer. Therefore, the concentration of sulfuric acid in the anolyte increases continuously over time. When the acid concentration reaches a predetermined threshold value, pure water is added to the system in order to re-establish the original concentration of sulfuric acid in the anolyte. The addition of water increases the total volume of the anolyte. A bleed is thus performed in the anolyte circuit loop following the water addition.

**[00101]** In practice, the maximum threshold concentration of sulfuric acid is established based on the following experimental observation: at a given operating temperature, the conductivity of the sulfuric acid first increases with concentration then

reaches a maximum and then decreases again. The highest concentration of acid, at which the ionic conductivity again equals the conductivity of the original acid concentration, is used as the upper threshold limit. For instance, at 50°C, starting with 30 wt.% sulfuric acid having a conductivity of 108.9 S/m, the conductivity increases up to 109.75 S/m for a concentration of 33 wt.% and then decreases down to 108.75 S/m for 36 wt.% H<sub>2</sub>SO<sub>4</sub> while at 60°C. Therefore, 36 wt.% H<sub>2</sub>SO<sub>4</sub> can be selected as the cut-off value. Once the cut-off value is reached, water is added until the acid concentration, as measured by means of a hydrometer, once again reaches 30 wt.%. The excess volume of sulfuric acid at 30 wt.% is then removed and recycled back to the process (*e.g.*, pickling, acid-pressure leaching), or its concentration can be further increased by usual techniques used to concentrate sulfuric acid, such as for instance but not restricted to, evaporation, evaporation under reduced pressure or vacuum, mechanical vapor recompression (MVR), reverse osmosis, dialysis, etc.

**[00102]** In an embodiment of the present invention, the central compartment is continuously replenished by the addition of iron-rich metal sulfate solution. It is to be noted that the pH of the iron-rich metal sulfate solution passing through the central compartment may or may not be adjusted prior to the electrolysis when using a three-compartment electrolyser. In yet a further embodiment, the central compartment may optionally be further replenished by adding copperas or any other suitable iron rich feedstock (**Figure 2**).

**[00103]** A number of parameters of the process of the present invention may be varied, as explained below.

**[00104]** Cathode materials suitable for use in the process of the present invention (used as bulk or as coating materials) are materials having a high hydrogen over-potential minimizing the evolution of hydrogen gas. In an embodiment of the present invention, the cathode materials have a hydrogen over-potential equal or higher

than that of pure iron under a given set of electrolysis conditions. Advantageously, the cathode material also allows stripping (*e.g.* mechanical stripping) of the iron metal deposit. Non limiting examples of suitable cathode materials include iron, steels, nickel, nickel alloy, titanium (of commercial or higher purity), titanium alloy (for example titanium palladium ASTM grade 7), zirconium (of commercial or higher purity), zirconium alloy, zinc (of commercial or higher purity), zinc alloy, cadmium (of commercial or higher purity), cadmium alloy, tin (of commercial or higher purity), tin alloy, copper (of commercial or higher purity), copper alloy, lead (of commercial or higher purity), lead alloy, niobium (of commercial or higher purity), niobium alloy, gold (of commercial or higher purity), gold alloy, mercury or metallic amalgam with mercury.

**[00105]** Anode materials suitable for use in the process of the present invention (used as bulk or coating materials) include:

**[00106]** (1) *dimensionally stable anodes* for the evolution of oxygen (DSA<sup>TM</sup>-O<sub>2</sub>) of the type [M/M<sub>x</sub>O<sub>y</sub>-A<sub>z</sub>O<sub>t</sub>] comprising a metallic substrate or base metal M coated with mixed metal oxides (MMO) as electrocatalyst, wherein:

**[00107]** **M** is a refractory metal or an alloy thereof with a valve action property; non-limiting examples include titanium, titanium alloy, zirconium, zirconium alloy, hafnium, hafnium alloy, vanadium, vanadium alloy, niobium, niobium alloy, tantalum and tantalum alloy;

**[00108]** **M<sub>x</sub>O<sub>y</sub>** is a metallic oxide of a valve metal forming a thin and impervious layer protecting the metallic substrate or base metal; non-limiting examples include TiO<sub>2</sub>, ZrO<sub>2</sub>, HfO<sub>2</sub>, NbO<sub>2</sub>, Nb<sub>2</sub>O<sub>5</sub>, TaO<sub>2</sub>, and Ta<sub>2</sub>O<sub>5</sub>; and

**[00109]**  $A_zO_t$  is an electrocatalytic metal oxide of a noble metal, an oxide of the platinum group metals (PGMs) non-limiting examples of which include  $RuO_2$ ,  $IrO_2$  and  $PtO_x$ , or a metallic oxide non-limiting examples of which include  $SnO_2$ ,  $Sb_2O_5$ ,  $Bi_2O_3$ ;

**[00110]** (2) *electronically conductive ceramics* such as sub-stoichiometric titanium oxides such as Magneli-Anderson phases with general formula  $Ti_nO_{2n-1}$  ( $n$  is an integer  $\geq 3$ );

**[00111]** (3) *conductive oxides* comprising a spinel structure  $AB_2O_4$ , wherein A is selected from the group consisting of Fe(II), Mn(II) and Ni(II); and B is selected from the group consisting of Al, Fe(III), Cr(III) and Co(III);

**[00112]** (4) *conductive oxides* comprising a perovskite structure  $ABO_3$ , wherein A is selected from the group consisting of Fe(II), Mn(II), Co(II) and Ni(II), and B is Ti(IV);

**[00113]** (5) *conductive oxides* comprising a pyrochlore structure  $AB_2O_7$  wherein A is selected from the group consisting of Fe(II), Mn(II), Co(II) and Ni(II), and B is Ti(IV);

**[00114]** (6) *carbon-based materials*, non-limiting examples of which include graphite, impervious graphite and vitreous carbon; or

**[00115]** (7) lead or lead alloys non-limiting examples of which include pure lead (>99.94 wt.% Pb), lead-silver (0.25-0.80 wt.% Ag), lead-tin (5-10 wt.% Sn), lead-antimony alloy (4-6 wt.% Sb), and lead-tin antimony (1-2 wt.% Sb and 3 to 4 wt.% Sn).

**[00116]** The anolyte composition used in the process of the present invention advantageously comprises sulfuric acid. In an embodiment of the present invention, the anolyte composition comprises a sulfuric acid concentration ranging from about 10 to about 60 wt.% sulfuric acid. In a further embodiment of the present invention, the sulfuric acid concentration comprises about 30 wt.% sulfuric acid.

**[00117]** In an embodiment of the present invention involving a three-compartment electrolyzer, the catholyte composition ranges from about 1 to about 800 g/L of iron (II) sulfate heptahydrate. In a further embodiment of the present invention involving a three-compartment electrolyzer, the catholyte composition comprises about 600 g/L of iron (II) sulfate heptahydrate. In yet a further embodiment of the present invention involving a three-compartment electrolyzer, the pH of the catholyte is maintained between about 0.5 to about 6.0. In yet a further embodiment of the present invention involving a three-compartment electrolyzer, the pH of the catholyte is maintained between about 1.0 to about 5.0. In yet a further embodiment of the present invention involving a three-compartment electrolyzer, the pH of the catholyte is maintained between about 1.5 to about 4.5. In yet a further embodiment of the present invention involving a three-compartment electrolyzer, the pH of the catholyte is maintained between about 2.0 to about 4.0.

**[00118]** In an embodiment of the present invention involving a three-compartment electrolyzer, the electrolysis is conducted at a temperature ranging between about 20°C to about 80°C. In a further embodiment of the present invention involving a three-compartment electrolyzer, the electrolysis is conducted at a temperature ranging between about 30°C to about 70°C. In yet a further embodiment of the present invention involving a three-compartment electrolyzer, the electrolysis is conducted at a temperature of about 50°C.

**[00119]** In an embodiment of the present invention, the flow rate of both anolyte and catholyte ranges from about 0.1 to about 100 L/min. In yet a further embodiment of the present invention, the flow rate of both anolyte and catholyte ranges from about 0.1 to about 50 L/min. In yet a further embodiment of the present invention, the flow rate of both anolyte and catholyte is about 2 L/min.

**[00120]** In an embodiment of the present invention, the electrolysis is conducted at a current density ranging from about 50 to about 3000 A/m<sup>2</sup>. Such a current density advantageously provides for a dendrite-free deposit of iron. In a further embodiment of the present invention, the electrolysis is conducted at a current density of about 2500 A/m<sup>2</sup>.

**[00121]** In an embodiment of the present invention, the electrolysis is conducted at a current density ranging from about 3000 to about 5000 A/m<sup>2</sup>. Such a current density advantageously provides for the production of iron chips. In a further embodiment of the present invention, the electrolysis is conducted at a current density of about 4000 A/m<sup>2</sup>.

**[00122]** In an embodiment of the present invention, the electrolysis is conducted at a current density ranging from about 5000 to about 10000 A/m<sup>2</sup>. Such a current density advantageously provides for the production of iron metal powder. In a further embodiment of the present invention, the electrolysis is conducted at a current density of about 7000 A/m<sup>2</sup>.

**[00123]** The separators as used in the process of the present invention may be passive, such as conventional diaphragm separators or active, such as ion exchange membranes. In an embodiment of the present invention, the anion and cation exchange membranes comprise conventional membranes.

ionic iron (Fe<sup>2+</sup>) is slowed down). A blanket of nitrogen gas was maintained above the solution further preventing any air oxidation. Small cm-sized polypropylene balls floating above the solution helped to prevent any important water loss by evaporation.

**[00129]            EXAMPLE 2**

**[00130]            Example 2a - Electrolysis of the iron-rich metal sulfate solution at pH 1.4 and 50°C.** The pH of the iron-rich metal sulfate solution of Example 1 was adjusted to 1.4 by adding minute amounts of iron (II) carbonate and then circulated inside the cathodic compartment of an electrolyzer. The electrolyzer consisted of a plate type electrolyzer (**Figure 5**) with two compartments separated by an anion-exchange membrane. The geometric electrode and membrane surface area was 929 cm<sup>2</sup> (square foot) and the spacing between each electrode and the separator was one inch (2.54 cm). The cathodic compartment was equipped with a cathode plate made of CP titanium (ASTM grade 2) supplied by RMI (Niles, OH). Prior to electrolysis, the cathode was chemically etched by immersing it into boiling oxalic acid (10 wt.% H<sub>2</sub>C<sub>2</sub>O<sub>4</sub>) and then rinsed thoroughly with deionized water until no trace of acid remained. The anodic compartment was equipped with a dimensionally stable anode (DSA<sup>TM</sup>-O<sub>2</sub>) of the type TiR-200® supplied by Eltech Systems (Chardon, OH), composed of a plate of CP titanium (substrate) coated with a high loading of iridium dioxide (IrO<sub>2</sub>) acting as electrocatalyst for promoting the evolution of oxygen (Ti/IrO<sub>2</sub>).

**[00131]**            The anolyte that circulated in the loop consisted of an aqueous solution of 30 wt.% sulfuric acid, the balance being deionised water. The electrolysis was performed galvanostatically at an overall current density of 700 A/m<sup>2</sup>. The operating temperature was 50°C and the volume flow rate of both catholyte and anolyte was 2 L/min. At the current density used, the measured overall cell voltage was 3.25 V. During the electrolysis, pure iron metal deposited at the cathode, while sulfate anions migrated through the permeable anion exchange membrane toward the anodic compartment where water was oxidized as oxygen gas at the surface of the anode, concurrently producing hydronium cations. The electrochemical reactions involved are as follows:

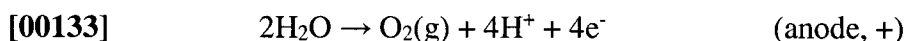
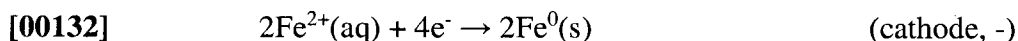

[00134] The overall reaction therefore being the production of iron metal at the cathode, and oxygen and sulfuric acid in the anodic compartment:

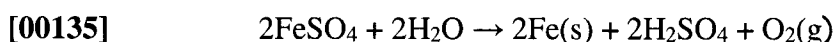

[00136] After two hours of continuous electrolysis, the power was shut off and the electrolyzer was opened. The electrodeposited smooth, gray thin plate was easily stripped from the titanium cathode by mechanical means. The measured mass was 129 g. After performing an ultimate chemical analysis of the bulk sample, it was made up of 99.99 wt.% iron. The estimated faradaic current efficiency was 95% and the specific energy consumption at 700 A/m<sup>2</sup> was 3.47 kWh per kg of pure iron.

[00137] **Example 2b - Electrolysis of the iron-rich metal sulfate solution at pH 2.8 and 60°C.** The pH of the iron-rich metal sulfate of Example 1 was adjusted to 2.8 (to not favor the evolution of hydrogen gas) by adding iron (II) carbonate and then circulated inside the cathodic compartment of the electrolyzer described hereinabove in Example 2a. The operating temperature was 60°C. The electrolysis was performed galvanostatically at an overall current density of 1000 A/m<sup>2</sup>. At the current density used, the measured overall cell voltage was 3.50 V. After two hours of continuous electrolysis, a bright, smooth electrodeposit was easily stripped from the titanium cathode by mechanical means. The measured mass was 190 g. After performing an ultimate chemical analysis of the sample, it was determined to be made up of 99.99 wt.% iron. The estimated faradaic current efficiency was 98% and the specific energy consumption at 1000 A/m<sup>2</sup> was 3.42 kWh per kg of pure iron.



[00138]           **Example 2c - Electrolysis of the iron-rich metal sulfate solution at pH 3.5 and 25°C.** The pH of the iron-rich metal sulfate of Example 1 was adjusted to 3.5 (to not favor the evolution of hydrogen gas) by adding iron (II) carbonate and then circulated inside the cathodic compartment of the electrolyzer described hereinabove in Example 2a. The operating temperature was 25°C. The electrolysis was performed galvanostatically at an overall current density of 300 A/m<sup>2</sup>. At the current density used, the measured overall cell voltage was 2.90 V. After two hours of continuous electrolysis, a bright, smooth electrodeposit was easily stripped from the titanium cathode by mechanical means. The measured mass was 55 g. After performing an ultimate chemical analysis of the sample, it was determined to be made up of 99.99 wt.% iron. The estimated faradaic current efficiency was 95% and the specific energy consumption at 300 A/m<sup>2</sup> was 2.93 kWh per kg of pure iron.

[00139]           **EXAMPLE 3**

[00140]           **Electrolysis of the iron-rich metal sulfate solution using a three-compartment electrolyzer.** The pH of the iron-rich metal sulfate of Example 1 was adjusted to 1.4 by adding iron (II) carbonate and then circulated inside the central compartment of the three-electrolyzer. The electrolyzer consisted of a plate type electrolyzer (**Figure 4**) with three compartments separated by an anion and a cation-exchange membrane. The geometric electrode and membrane surface area was 929 cm<sup>2</sup> (square foot) and the spacing between each electrode and the separator was one inch (2.54 cm). The spacing between each membrane was one inch (2.54 cm).

[00141]           The cathodic compartment was equipped with a cathode plate made of CP titanium (ASTM grade 2) supplied by RMI (Niles, OH). Prior to electrolysis, the cathode was chemically etched by immersing it into boiling oxalic acid (10 wt.% H<sub>2</sub>C<sub>2</sub>O<sub>4</sub>) and then rinsed thoroughly with deionized water until no trace of acid remained.

**[00142]** The anodic compartment was equipped with a dimensionally stable anode (DSA<sup>TM</sup>-O<sub>2</sub>) of the type TiR-2000® supplied by Eltech Systems (Chardon, OH), composed of a plate of CP titanium (substrate) coated with a high loading of iridium dioxide (IrO<sub>2</sub>) acting as electrocatalyst for promoting the evolution of oxygen (Ti/IrO<sub>2</sub>).

**[00143]** The catholyte that circulated in the loop within the cathodic compartment consisted of an aqueous solution of 600 g/L iron (II) sulfate heptahydrate at a pH of 1.4, while the anolyte that circulated in the loop within the anodic compartment consisted of an aqueous solution of 30 wt.% sulfuric acid, the balance being deionised water.

**[00144]** The electrolysis was performed galvanostatically at an overall current density of 1000 A/m<sup>2</sup>. The operating temperature was 50°C and the volume flow rate of catholyte, anolyte and iron-rich solution was 2 L/min. At the current density used, the measured overall cell voltage was 3.90 V.

**[00145]** During the electrolysis, ferrous cations from the iron-rich metal sulfate solution crossed the cation exchange membrane and pure iron metal deposited at the cathode. Sulfate anions migrated through the permeable anion exchange membrane toward the anodic compartment where water was oxidized as oxygen gas at the surface of the anode concurrently producing hydronium cations.

**[00146]** After two hours of continuous electrolysis, the power was shut off and the electrolyzer was opened. The electrodeposited bright iron metal was easily stripped from the titanium cathode by mechanical means. The measured mass was 184 g. The estimated faradaic current efficiency was 95% and the specific energy consumption at 1000 A/m<sup>2</sup> was 3.94 kWh per kg of pure iron.

[00147] The results and characteristics of the electrolysis experiments conducted in Examples 2a, 2b, 2c, and 3 are summarized hereinbelow in **Table 1**.

[00148] **Table 1: Results and Characteristics of Electrolysis Experiments**

	<b>Example 2a</b>	<b>Example 2b</b>	<b>Example 2c</b>	<b>Example 3</b>
pH of the Catholyte (25°C)	1.4	2.8	3.5	1.4
Temperature of the Catholyte (°C)	50	60	25	50
Electrolyzer Design (# compartments)	2	2	2	3
Cathodic Current Density (A/m <sup>2</sup> )	700	1000	300	1000
Cell Voltage (U <sub>cell</sub> /V)	3.25	3.50	2.90	3.80
Faradaic Current Efficiency (%)	95	98	95	95
Iron Specific Energy Consumption (kWh/kg)	3.470	3.420	2.930	3.800

[00149] It is to be understood that the invention is not limited in its application to the details of construction and parts as described hereinabove. The invention is capable of other embodiments and of being practiced in various ways. It is also understood that the phraseology or terminology used herein is for the purpose of description and not limitation. Hence, although the present invention has been described hereinabove by way of illustrative embodiments thereof, it can be modified. The scope of the claims should not be limited by the embodiments and examples, but should be given the broadest interpretation consistent with the description as a whole.

**REFERENCES**

1. Fisher, F. Process for the manufacture of ductile electrolytic iron - US patent 992,951 issued on May 23, 1911.
2. Cleaves, H. E.; and Thompson, J. G. *The Metal Iron*. Part 1 – Preparation of High Purity Iron, Chapter 1 and 2, pages 3-60. Alloys of Iron Research Monograph Series, McGraw-Hill, New York (1935).
3. Burges, C. F. *Trans American Electroplaters Society* 5, 201 (1904).
4. Cowper-Coles, S. O. An improved process for the production of iron by electrodeposition - British Patent 191028226 (Issued December 5, 1910)
5. Mostad, E., Rolseth, S. and Thonstad, J. Electrowinning of iron from sulphate solutions. *Hydrometallurgy*, 90(2-4) 213-220 (2008).
6. Lahitte, C.; Hita, A.; Schneider, H.; Durand, G.; Pareau, D. and Stambouli, M. Regeneration by liquid-liquid extraction of acids from aqueous solutions containing metals (WO 02081779A2).
7. Cardarelli, F. *Materials Handbook: a Concise Desktop Reference. Second Edition*. Springer London, New York, pages 556-590 (2008).

**WHAT IS CLAIMED IS:**

1. An electrochemical process for the recovery of metallic iron or an iron-rich alloy, oxygen and sulfuric acid from an iron-rich metal sulfate solution, said process comprises:
  - a) providing an iron-rich metal sulfate solution;
  - b) electrolyzing said iron-rich metal sulfate solution in an electrolyzer comprising a cathodic compartment equipped with a cathode having a hydrogen over-potential equal or higher than that of iron and containing a catholyte having a pH ranging from 2 to 6; an anodic compartment equipped with an anode and containing an anolyte; and a separator allowing for anion passage; and
  - c) recovering electrodeposited iron or iron-rich alloy, sulfuric acid and oxygen gas;

wherein:

electrolyzing said iron-rich metal sulfate solution causes iron or an iron-rich alloy to be electrodeposited at the cathode, nascent oxygen gas to evolve at the anode, sulfuric acid to accumulate in said anodic compartment and an iron depleted solution to be produced.

2. The electrochemical process of claim 1, wherein step a) includes leaching an iron rich feedstock to produce a slurry; and subjecting said slurry to a separation step to provide the iron-rich metal sulfate solution.
3. The electrochemical process of claim 1, wherein the iron-depleted solution is replenished with fresh iron-rich metal sulfate solution and recirculated.
4. The electrochemical process of claim 1, further comprising the step of etching the cathode prior to the electrolyzing step.
5. The electrochemical process of claim 1, wherein the pH of the catholyte is adjusted to a pH ranging from 2 to 4.
6. The electrochemical process of claim 1, wherein the cathode has an over-voltage at 200 A.m<sup>-2</sup> of greater than 466 mV in 0.5 mol.dm<sup>-3</sup> H<sub>2</sub>SO<sub>4</sub> solution at 25°C and an over-voltage at 1000 A.m<sup>-2</sup> of greater than 800 mV in 1.0 mol.dm<sup>-3</sup> H<sub>2</sub>SO<sub>4</sub> solution at 25°C.

7. The electrochemical process of claim 1, wherein the cathode comprises a material or is coated with a material selected from the group consisting of nickel, nickel alloy, iron, iron alloy, titanium, titanium alloy, zirconium, zirconium alloy, zinc, zinc alloy, cadmium, cadmium alloy, tin, tin alloy, copper, copper alloy, lead, lead alloy, niobium, niobium alloy, gold, gold alloy, mercury and a metallic amalgam including mercury.
8. The electrochemical process of claim 7, wherein the cathode comprises or is coated with titanium or titanium alloy.
9. The electrochemical process of claim 8, wherein the titanium alloy is a titanium palladium alloy.
10. The electrochemical process of claim 4, wherein the etching step comprises treating the cathode with an acid.
11. The electrochemical process of claim 10, wherein the acid is selected from the group consisting of oxalic acid and a mixture of fluoro and nitric acid.
12. The electrochemical process of claim 1, wherein the anolyte comprises a sulfuric acid solution.
13. The electrochemical process of claim 12, wherein the sulfuric acid solution comprises a concentration ranging from 5 to 60 wt.%.
14. The electrochemical process of claim 13, wherein the sulfuric acid solution comprises a concentration of 30 wt.%.
15. The electrochemical process of claim 12, wherein the anolyte circulates in a loop within the anodic compartment.
16. The electrochemical process of claim 1, wherein the iron-rich metal sulfate solution acting as the catholyte circulates in a loop within the cathodic compartment.

- 17.** The electrochemical process of claim **1**, wherein the anode is a dimensionally stable anode either comprising
- i) a material of the formula  $M/M_xO_y-A_zO_t$ , wherein:
    - a) M is a refractory metal or an alloy with a valve action property;
    - b)  $M_xO_y$  is a metallic oxide of a valve metal; and
    - c)  $A_zO_t$  is an electrocatalytic metal oxide of a noble metal, an oxide of the platinum group metals or a metallic oxide;
  - ii) an electronically conductive ceramic material;
  - iii) a conductive oxide having a spinel structure  $AB_2O_4$ , wherein
    - a) A is selected from the group consisting of Fe(II), Mn(II) and Ni(II); and
    - b) B is selected from the group consisting of Al, Fe(III), Cr(III) and Co(III);
  - iv) a conductive oxide having a perovskite structure  $ABO_3$ , wherein
    - a) A is selected from the group consisting of Fe(II), Mn(II), Co(II) and Ni(II);  
and
    - b) B is Ti(IV);
  - v) a conductive oxide having a pyrochlore structure  $AB_2O_7$ , wherein
    - a) A is selected from the group consisting of Fe(II), Mn(II), Co(II) and Ni(II);  
and
    - b) B is Ti(IV);
  - vi) a carbon based material; or
  - vii) a lead or lead alloy.
- 18.** The electrochemical process of claim **17**, wherein the refractory metal or the alloy of the refractory metal is selected from the group consisting of titanium, titanium alloy, zirconium, zirconium alloy, hafnium, hafnium alloy, vanadium, vanadium alloy, niobium, niobium alloy, tantalum and tantalum alloy.
- 19.** The electrochemical process of claim **17**, wherein the metallic oxide of a valve metal is selected from the group consisting of  $TiO_2$ ,  $ZrO_2$ ,  $HfO_2$ ,  $NbO_2$ ,  $Nb_2O_5$ ,  $TaO_2$ , and  $Ta_2O_5$ .

20. The electrochemical process of claim 17, wherein the oxide of the platinum group metals is selected from the group consisting of  $\text{RuO}_2$ ,  $\text{IrO}_2$  and  $\text{PtO}_x$ .
21. The electrochemical process of claim 17, wherein the metallic oxide is selected from the group consisting of  $\text{SnO}_2$ ,  $\text{Sb}_2\text{O}_5$  or  $\text{Bi}_2\text{O}_3$ .
22. The electrochemical process of claim 19, wherein the metallic oxide of a valve metal forms a thin impervious protective layer over the refractory metal or the alloy of the refractory metal.
23. The electrochemical process of claim 17, wherein the ceramic material comprises titanium oxides having the general formula  $\text{Ti}_n\text{O}_{2n-1}$ , wherein n is an integer equal to or higher than 3.
24. The electrochemical process of claim 17, wherein the carbon based material is selected from the group consisting of graphite, impervious graphite and vitreous carbon.
25. The electrochemical process of claim 17, wherein the lead alloy is selected from the group consisting of lead-silver alloys, lead-tin alloys, lead-antimony alloys, and lead-tin antimony alloys.
26. The electrochemical process of claim 1, wherein step b) is performed in a two-compartment electrolyser comprising an ion exchange membrane separating the anodic compartment from the cathodic compartment.
27. The electrochemical process of claim 26, wherein the ion exchange membrane is an anion-exchange membrane.
28. The electrochemical process of claim 1, wherein step b) is performed in a three-compartment electrolyser comprising a central compartment disposed between the anodic compartment and the cathodic compartment and wherein an ion exchange membrane separates the anodic and cathodic compartments from the central compartment.



29. The electrochemical process of claim 28, wherein an anion exchange membrane separates the anodic compartment from the central compartment and wherein a cation exchange membrane separates the cathodic compartment from the central compartment.
30. The electrochemical process of claim 29, wherein the iron-rich metal sulfate solution is circulated within the central compartment.
31. The electrochemical process of claim 28, wherein the catholyte circulates in a loop within the cathodic compartment.
32. The electrochemical process of claim 31, wherein the catholyte comprises an iron (II) sulfate heptahydrate solution.
33. The electrochemical process of claim 32, wherein the catholyte comprises an iron (II) sulfate heptahydrate solution having a concentration ranging from 1 to 800 g/L.
34. The electrochemical process of claim 33, wherein the catholyte comprises an iron (II) sulfate heptahydrate solution having a concentration of 600 g/L.
35. The electrochemical process of any one of claims 15, 16 or 31, wherein the anolyte or catholyte comprises a flow rate ranging from 0.1 L/min to 100 L/min.
36. The electrochemical process of claim 35, wherein the flow rate ranges from 0.1 L/min to 30 L/min.
37. The electrochemical process of claim 36, wherein the flow rate is 2 L/min.
38. The electrochemical process of claim 1, wherein step b) is performed under constant current and at a current density ranging from 50 to 10000 A/m<sup>2</sup>.
39. The electrochemical process of claim 38, wherein the current density ranges from 50 to 5000 A/m<sup>2</sup>.
40. The electrochemical process of claim 39, wherein the current density is 2500 A/m<sup>2</sup>.

41. The electrochemical process of claim 38, wherein the current density ranges from 3000 to 5000 A/m<sup>2</sup>.
42. The electrochemical process of claim 41, wherein the current density is 4000 A/m<sup>2</sup>.
43. The electrochemical process of claim 38, wherein the current density ranges from 5000 to 10000 A/m<sup>2</sup>.
44. The electrochemical process of claim 43, wherein the current density is 7000 A/m<sup>2</sup>.
45. The electrochemical process of claim 1, wherein step b) is performed at a temperature ranging from 20 to 100°C.
46. The electrochemical process of claim 45, wherein the temperature ranges from 30°C to 70°C.
47. The electrochemical process of claim 46, wherein the temperature is 50°C.
48. The electrochemical process of claim 1, wherein the recovered nascent oxygen gas is further dried and liquefied.
49. The electrochemical process of claim 1, wherein the recovered sulfuric acid is at least one of concentrated and recirculated.

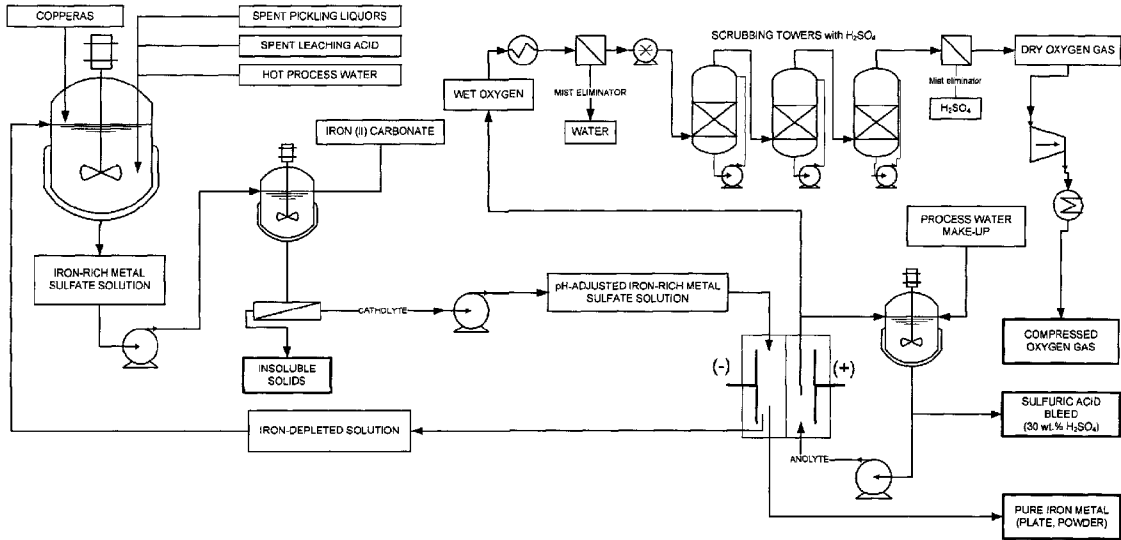

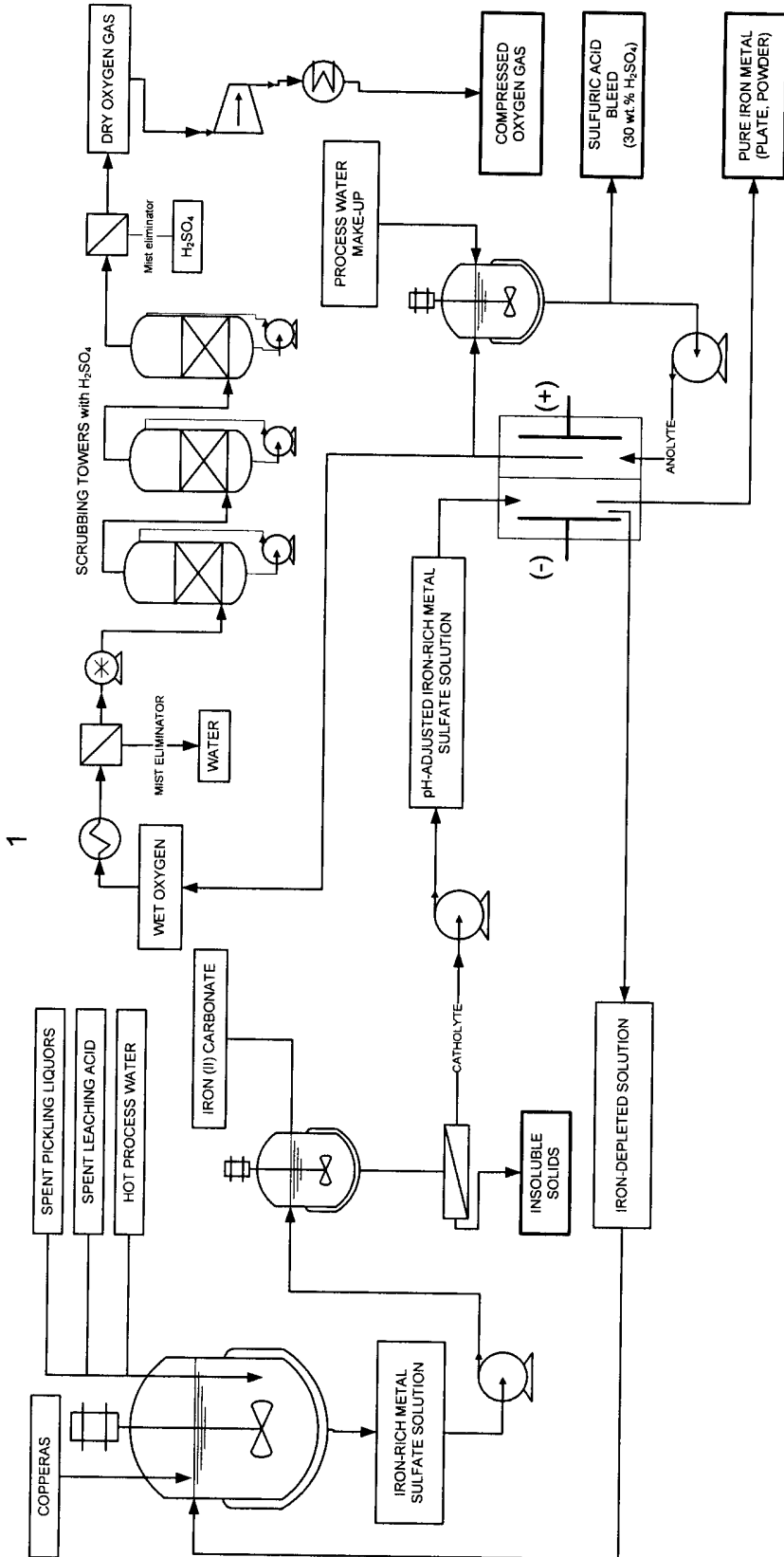

Figure 1

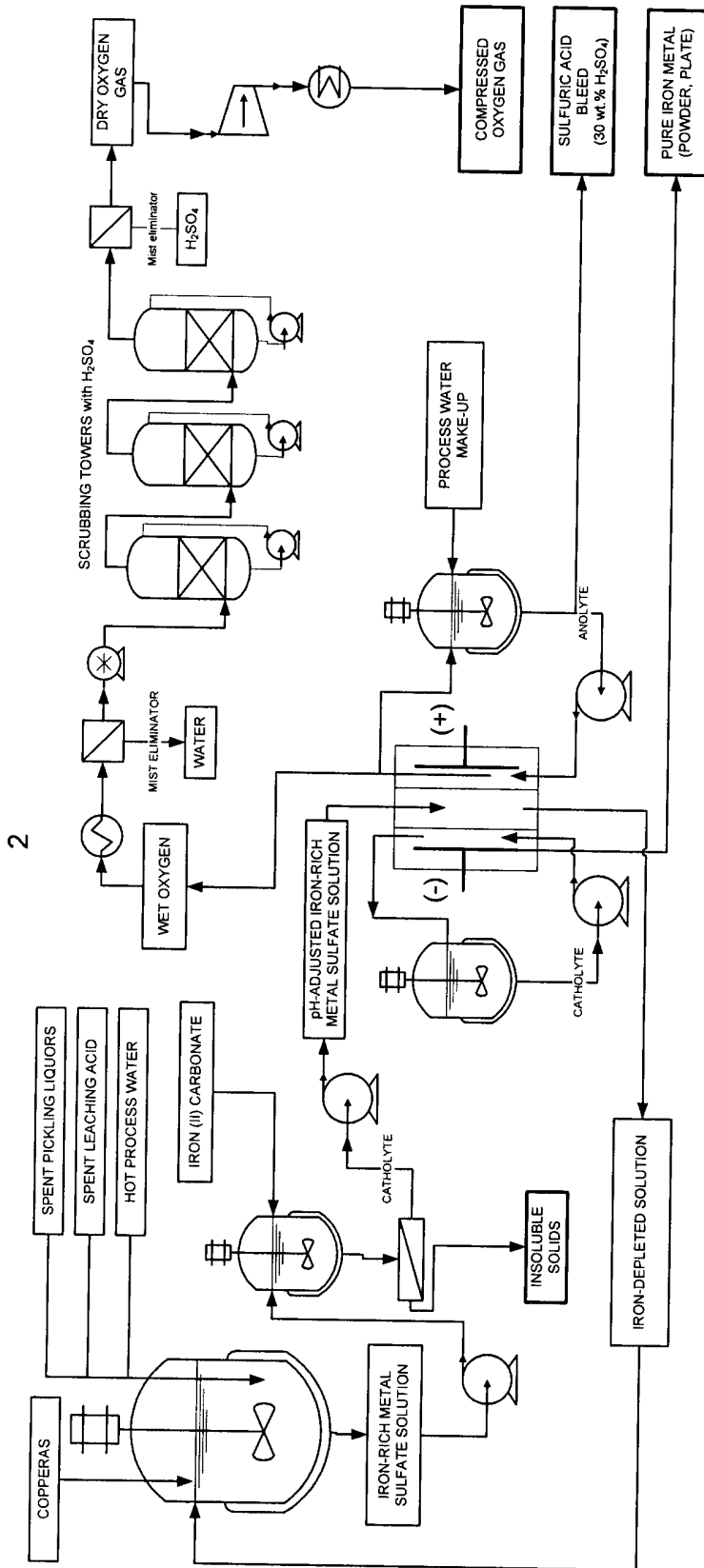

Figure 2

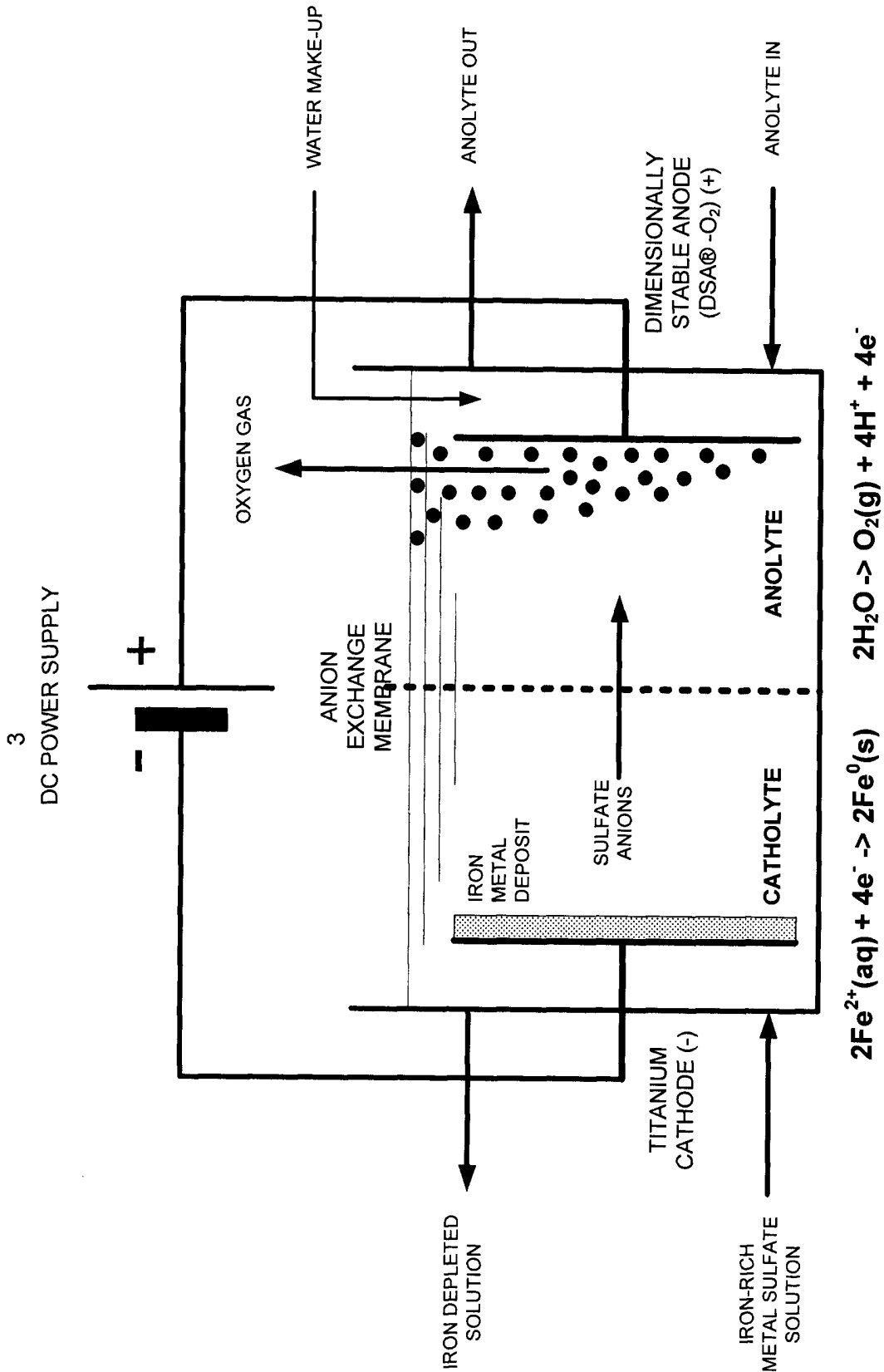

Figure 3

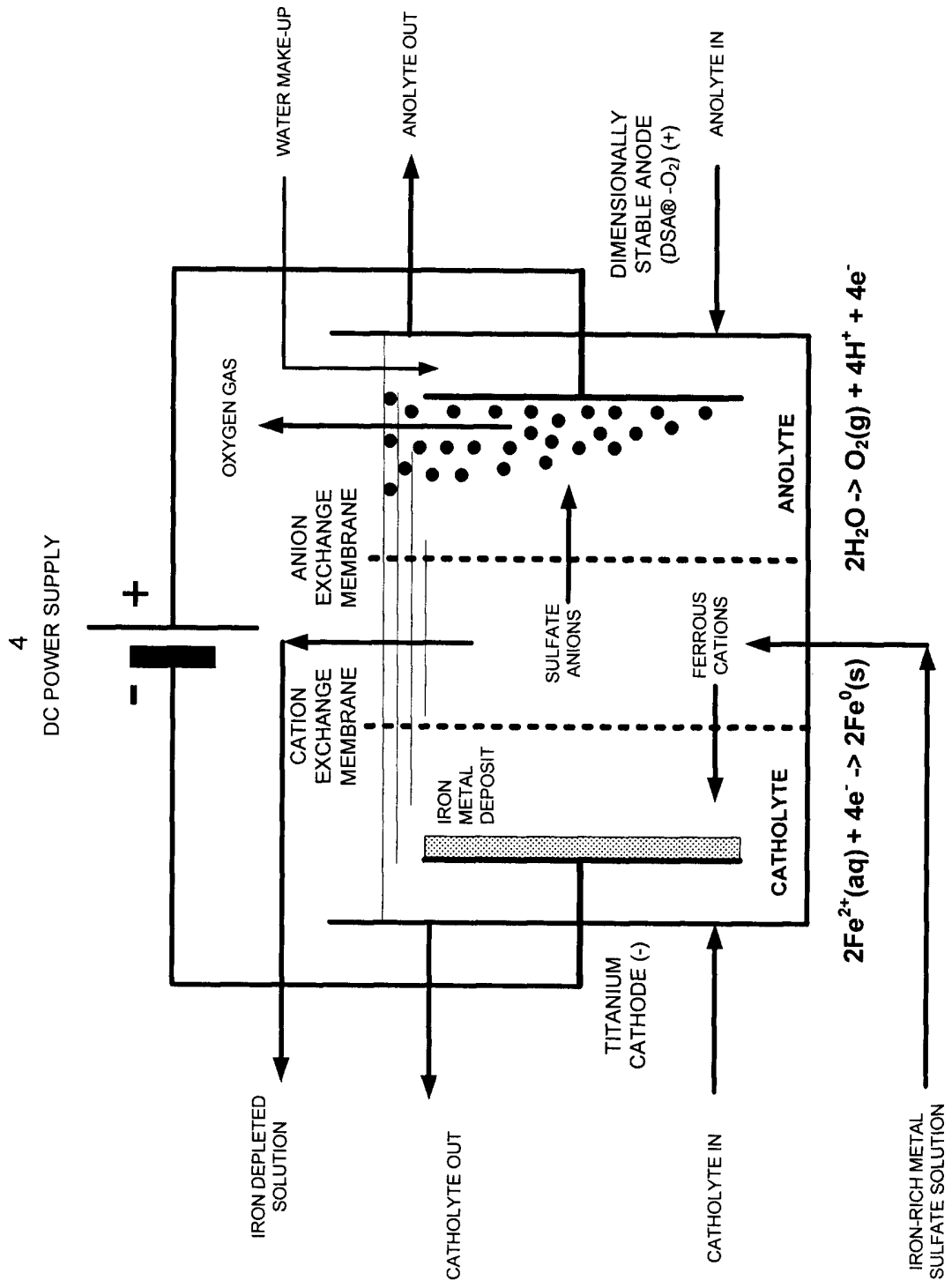

Figure 4

5

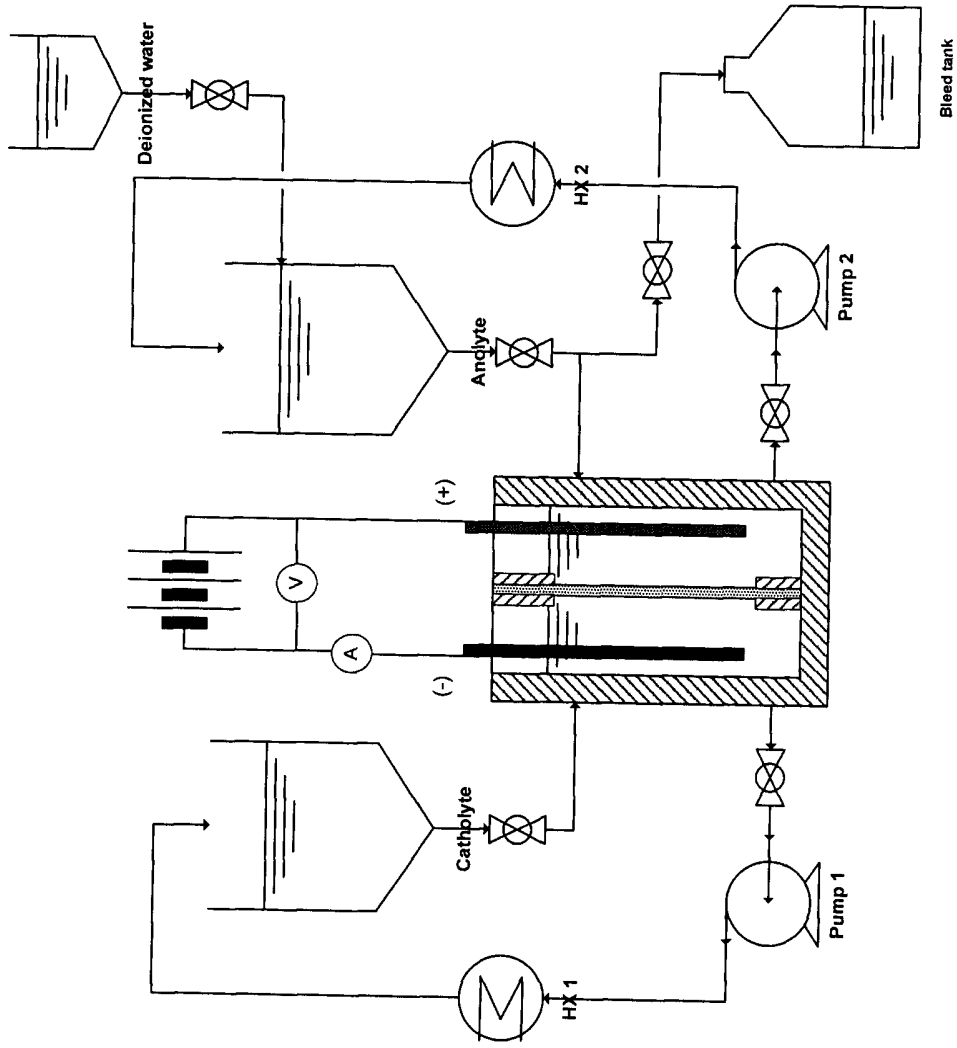

Figure 5